

## Standard Reeve Crane Blocks 3 Sheaves

---

### Product information



#### General:

- Standard Reeve Crane Blocks may be used on a wide variety of land based cranes such as mobile and crawler cranes. They are an excellent choice where frequent easy block change is not a required main feature, or lifting height is limited.
- Double sealed maintenance free roller bearings.
- Design Factor of Safety of 4:1.
- Forged high tensile steel DIN hooks.
- Ductile iron sheaves, featuring graphite lubricated groove.
- High impact resistant side plates.
- Operational temperature range -40 up to +80°C.
- Lubrication on hook suspension.
- Short design for increased lifting height.
- Safety latch with locking pin.
- C3M finish in signal yellow.

#### Options:

- Double hook.
- Double hook with shackle hole.
- Quad hook.
- Shackle stud eye.

#### Important:

**Inquiries for custom versions are welcome!**

... [Read more](#)

---

## Standard Reeve Crane Blocks 3 Sheaves

### Blueprint

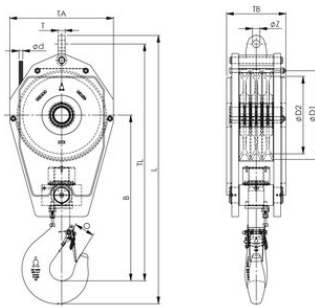

### Technical data

| WLL ton | Model                  | Rope Ø mm | Hooksize | Weight kg |
|---------|------------------------|-----------|----------|-----------|
| 25      | SRB 260 .14 .3 .25 .E  | 14        | 8        | 210       |
| 25      | SRB 260 .16 .3 .25 .E  | 16        | 8        | 210       |
| 29      | SRB 285 .16 .3 .29 .E  | 16        | 8        | 210       |
| 29      | SRB 320 .16 .3 .29 .E  | 16        | 8        | 225       |
| 32      | SRB 355 .19 .3 .32 .E  | 19        | 10       | 325       |
| 40      | SRB 360 .19 .3 .40 .E  | 19        | 12       | 455       |
| 40      | SRB 400 .22 .3 .40 .E  | 22        | 12       | 500       |
| 50      | SRB 400 .22 .3 .50 .E  | 22        | 16       | 500       |
| 50      | SRB 400 .22 .3 .50 .E  | 22        | 16       | 540       |
| 63      | SRB 450 .22 .3 .63 .E  | 22        | 16       | 680       |
| 63      | SRB 450 .24 .3 .63 .E  | 24        | 16       | 770       |
| 63      | SRB 450 .26 .3 .63 .E  | 26        | 16       | 770       |
| 80      | SRB 528 .26 .3 .80 .E  | 24        | 20       | 1,270     |
| 80      | SRB 528 .26 .3 .80 .E  | 26        | 20       | 1,270     |
| 100     | SRB 528 .26 .3 .100 .E | 26        | 25       | 1,270     |
| 100     | SRB 528 .28 .3 .100 .E | 28        | 25       | 1,270     |
| 125     | SRB 670 .28 .3 .125 .E | 28        | 25       | 2,900     |
| 125     | SRB 670 .32 .3 .125 .E | 32        | 25       | 2,900     |