

## Hand pallet truck Proline with short forks

---

### Product information

**General:**

Hand pallet truck PROLINE with short forks. Capacity 2500 kg. For the professional transportation of short palletised goods and box pallets under demanding conditions.

- Ergonomic rubber control handle for safe handling.
- Low maintenance high performance hydraulic pump with hard chromium plated piston and pressure relief valve.
- Frame and forks in robust steel construction, adjustable connecting rods, especially hardened axles and the high quality powder coating ensure a long life expectancy.
- Fork lengths from 800 up to 1000 mm for transportation of small loads.
- Steering angle of 105 degree to each side for easy handling in confined spaces.
- Available with tandem (TS) or single rollers (ES).

... [Read more](#)

---

**Features:** - Ergonomic safety control handle for one-hand operation of lifting, driving and lowering.

## Hand pallet truck Proline with short forks

### Blueprint

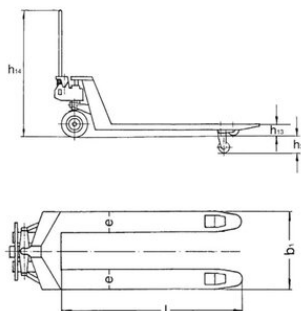

### Technical data

Part code	Type	Wheels	Capacity kg	h3 mm	l mm	B1mm mm	h14mm mm	h13mm mm	e mm	Weight kg
034527150	HU 25-80 EP	VG/PUR	2,500	115	800	540	1,230	85	160	63
034527153	HU 25-80 TP	VG/PUR	2,500	115	800	540	1,230	85	160	64
034527155	HU 25-100 TP	VG/PUR	2,500	115	1,000	540	1,230	85	160	66
034527154	HU 25-90 TP	VG/PUR	2,500	115	900	540	1,230	85	160	67